



Designation: D3164 – 03 (Reapproved 2017)

# Standard Test Method for Strength Properties of Adhesively Bonded Plastic Lap-Shear Sandwich Joints in Shear by Tension Loading<sup>1</sup>

This standard is issued under the fixed designation D3164; the number immediately following the designation indicates the year of original adoption or, in the case of revision, the year of last revision. A number in parentheses indicates the year of last reapproval. A superscript epsilon ( $\epsilon$ ) indicates an editorial change since the last revision or reapproval.

## 1. Scope

1.1 This test method is intended to complement Test Method D1002 and Test Method D3163 and extend its application to single-lap-shear adhesive joints employing plastic adherends. The test method is useful for generating comparative shear strength data for joints made from a number of plastics. It can also provide a means by which several plastics surface treatments can be compared.

1.2 The values stated in SI units are to be regarded as the standard. The values given in parentheses are for information only.

NOTE 1—A complete metric companion to Test Method D3164 has been developed — D3164M.

1.3 *This standard does not purport to address all of the safety concerns, if any, associated with its use. It is the responsibility of the user of this standard to establish appropriate safety and health practices and determine the applicability of regulatory limitations prior to use.*

1.4 *This international standard was developed in accordance with internationally recognized principles on standardization established in the Decision on Principles for the Development of International Standards, Guides and Recommendations issued by the World Trade Organization Technical Barriers to Trade (TBT) Committee.*

## 2. Referenced Documents

2.1 *ASTM Standards:*<sup>2</sup>

D907 Terminology of Adhesives

D1002 Test Method for Apparent Shear Strength of Single-Lap-Joint Adhesively Bonded Metal Specimens by Tension Loading (Metal-to-Metal)

<sup>1</sup> This test method is under the jurisdiction of ASTM Committee D14 on Adhesives and is the direct responsibility of Subcommittee D14.40 on Adhesives for Plastics.

Current edition approved April 1, 2017. Published May 2017. Originally approved in 1973. Last previous edition approved in 2011 as D3164 – 03 (2011). DOI: 10.1520/D3164-03R17.

<sup>2</sup> For referenced ASTM standards, visit the ASTM website, www.astm.org, or contact ASTM Customer Service at service@astm.org. For *Annual Book of ASTM Standards* volume information, refer to the standard's Document Summary page on the ASTM website.

D2093 Practice for Preparation of Surfaces of Plastics Prior to Adhesive Bonding

D2651 Guide for Preparation of Metal Surfaces for Adhesive Bonding

D3163 Test Method for Determining Strength of Adhesively Bonded Rigid Plastic Lap-Shear Joints in Shear by Tension Loading

D3164M Test Method for Strength Properties of Adhesively Bonded Plastic Lap-Shear Sandwich Joints in Shear by Tension Loading (Withdrawn 2012)<sup>3</sup>

D4896 Guide for Use of Adhesive-Bonded Single Lap-Joint Specimen Test Results

E4 Practices for Force Verification of Testing Machines

## 3. Terminology

3.1 *Definitions*—Many terms in this test method are defined in Terminology D907.

## 4. Significance and Use

4.1 Due to the increased use of adhesively bonded plastics as a result of the inherent advantages afforded by bonded rather than mechanically fastened joints, particularly the alleviation of stress risers and stress cracking, there is a need for standard tests by which joints of various substrates and adhesives can be compared. This test method is intended to meet such a need.

4.2 This test method is limited to test temperatures below the softening point of the subject adherends, and is not intended for use on anisotropic adherends such as reinforced plastic laminates.

4.3 The misuse of strength values obtained from this test method as design stress allowable values for structural joints could lead to product failure, property damage, and human injury.

4.4 The apparent shear strength of an adhesive obtained from a given small single-lap specimen may differ from that obtained from a joint made with different adherends or by a different bonding process. The normal variation of temperature and moisture in the service environment causes the adherends

<sup>3</sup> The last approved version of this historical standard is referenced on www.astm.org.

and the adhesive to swell and shrink. The adherends and adhesive are likely to have different thermal and moisture coefficients of expansion.

4.5 Even in small specimens, short-term environmental changes can induce internal stresses or chemical changes in the adhesive that permanently affect the apparent strength and other mechanical properties of the adhesive. The problem of predicting joint behavior in a changing environment is even more difficult if a different type of adherend is used in a larger structural joint than was used in the small specimen.

4.6 The apparent shear strength measured with a single-lap specimen is not suitable for determining allowable design stresses for designing structural joints that differ in any manner from the joints tested without thorough analysis and understanding of the joint and adhesive behaviors.

4.7 Single-lap tests may be used for comparing and selecting adhesives or bonding processes for susceptibility to fatigue and environmental changes, but such comparisons must be made with great caution since different adhesives may respond differently in different joints. See Guide D4896 for further discussion of the concepts relative to interpretation of adhesive bonded single lap joints.

**5. Apparatus**

5.1 *Testing Machine*, conforming to the requirements of and having the capabilities of the machine prescribed in Test Method D1002 and has an accuracy of  $\pm 1\%$  when calibrated in accordance with Practices E4 requirements. Likewise the grips are capable of securely grasping the specimen throughout the test without allowing the specimen to slip. The grips are also self-aligning.

5.2 *Temperature and Relative Humidity Controlling Equipment*, capable of maintaining the test temperature to

$\pm 3^\circ\text{C}$  ( $\pm 5^\circ\text{F}$ ) and the relative humidity to  $\pm 3\%$ . If ambient laboratory conditions are employed the same degree of control is required.

**6. Test Specimen**

6.1 Make specimens that conform to the form and dimensions shown in Fig. 1. It is recommended that the test specimens be cut from the test panel depicted in Fig. 2, but individual specimens may be prepared if preferred. The recommended metal substrate is Alloy 2024-T3 aluminum,  $1.62 \pm 0.125\text{ mm}$  ( $0.064 \pm 0.005\text{ in.}$ ). A surface treatment such as Method A of Guide D2651 is recommended for the aluminum. If a metal substrate other than aluminum is employed, then one of the other surface preparations in Guide D2651 is suggested. The recommended length of overlap is  $12.7 \pm 0.25\text{ mm}$  ( $0.5 \pm 0.01\text{ in.}$ ). The thickness of the plastic in the metal/adhesive/plastic/adhesive/metal sandwich configuration may vary depending on the type and manufacturer but thin films of  $0.354\text{ mm}$  ( $0.010\text{ in.}$ ) or less are recommended. An upper limit of  $1.62\text{ mm}$  ( $0.064\text{ in.}$ ) plastic thickness is suggested.

6.2 The surface preparation used on the adherend depends on the subject plastic adherend. Methods such as those recommended in Practice D2093 serve as a useful guide.

6.3 Apply the adhesive in accordance with the manufacturer’s recommendations. Choose the adhesive such that the cure temperature does not adversely affect the mechanical properties of the adherend.

6.4 Cut test specimens from the bonded panels pictured in Fig. 2. Cutting the specimens must be accomplished without overheating or otherwise physically damaging the adherend or bonded interface. Individual test specimens may also be prepared if desired.

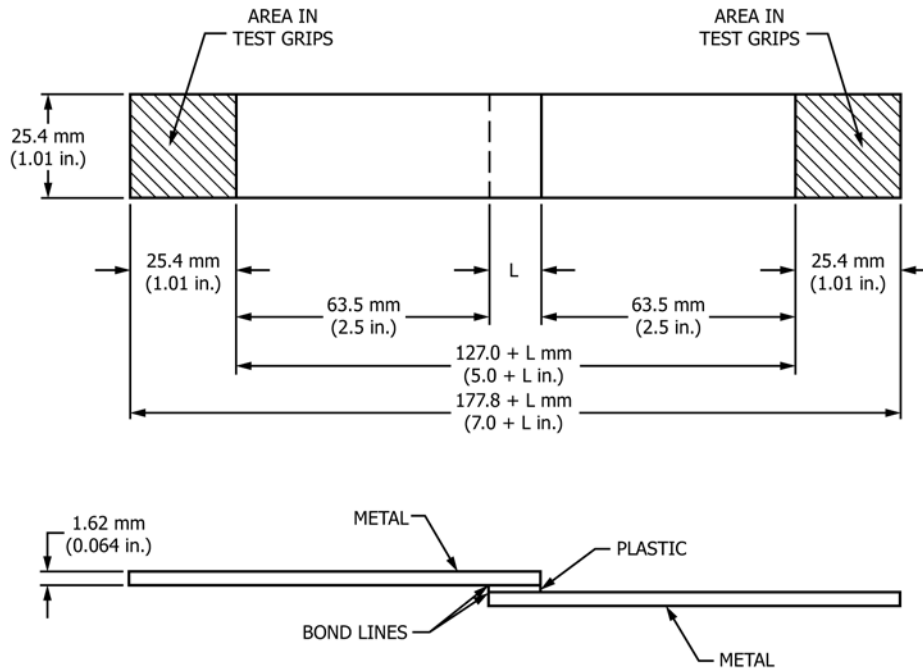

FIG. 1 Form A—Dimensions of Test Specimen